

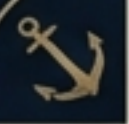

# **Moby Dick: Deconstructing Melville's Leviathan**

An Analytical Review of Narrative Architecture, Philosophical Metaphysics, and Madness.

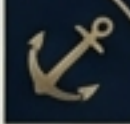

# The Dual Nature of the Beast

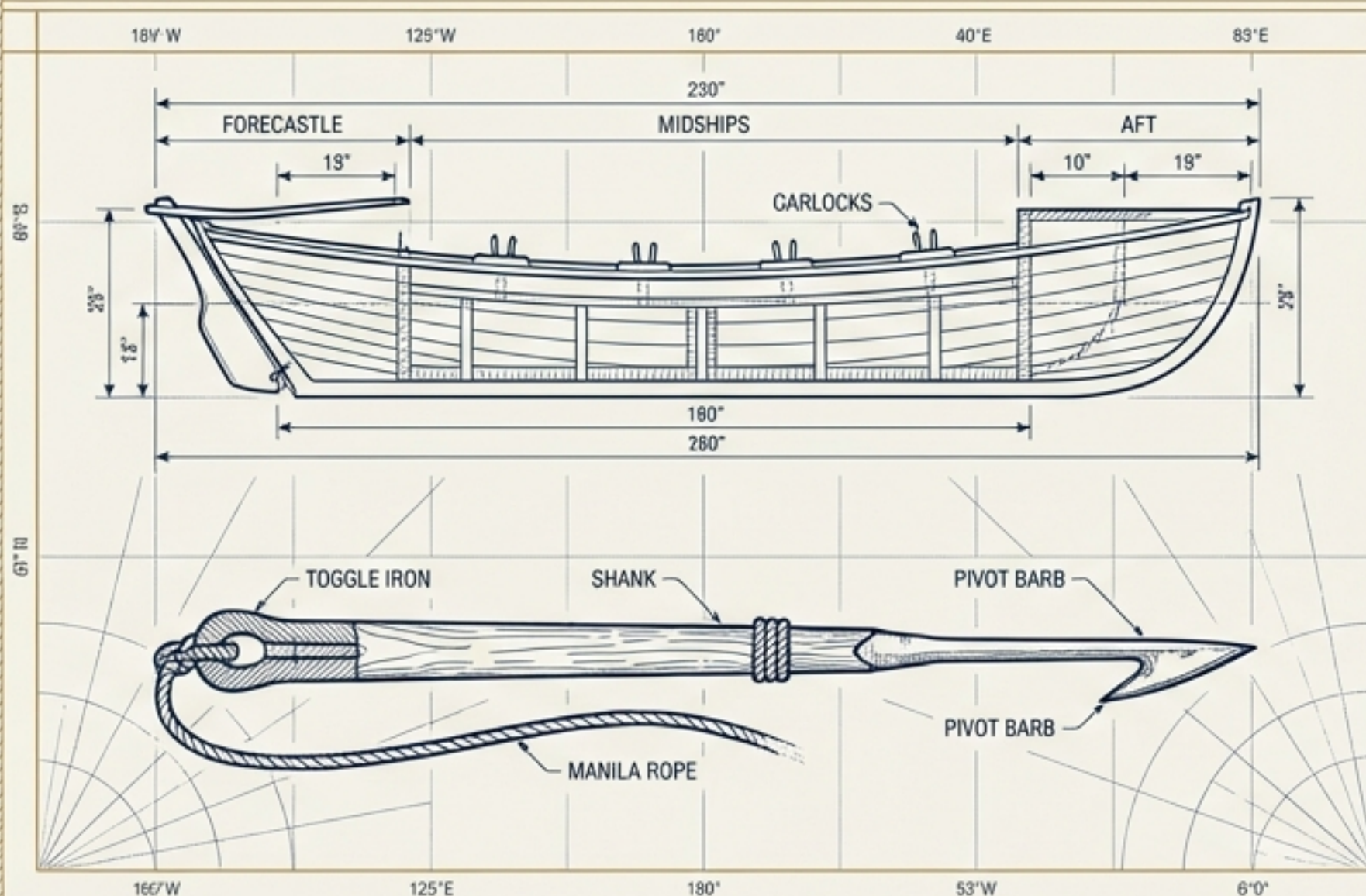

## The Material: *The Whaling Manual*

A granular, exhaustively researched documentary of the 19th-century Nantucket whaling industry, grounded in blood, oil, and commerce.

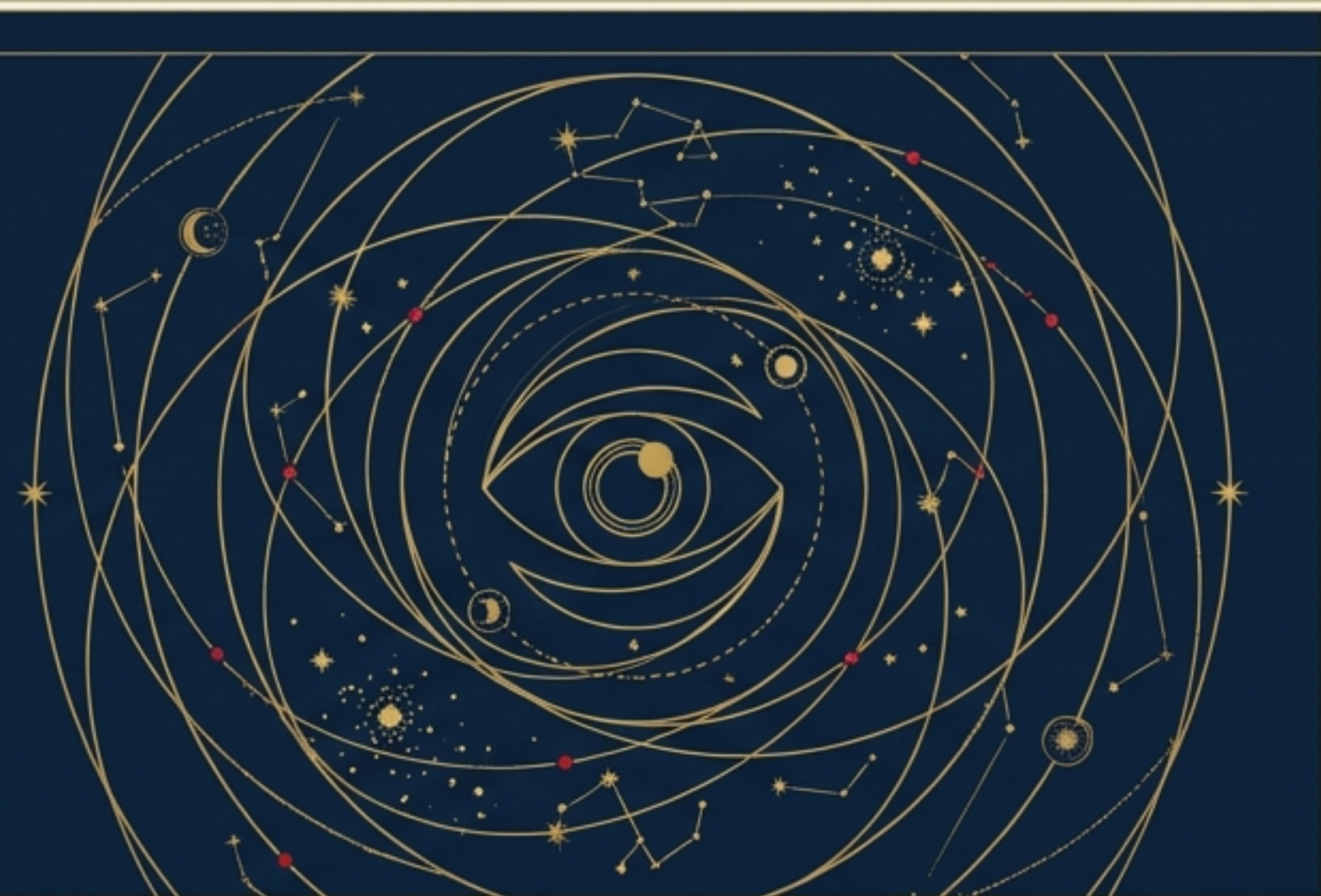

## The Metaphysical: *The Philosophical Encyclopedia*

A vast, ambitious exploration of theology, existential dread, and human nature masquerading as an adventure tale.



To understand the infinite soul of the universe, Melville demands we first exhaust the finite, physical reality of the world.



# Ishmael's Substitute for Pistol and Ball



Ishmael goes to sea to cure a damp, drizzly November in my soul.  
He is the ultimate Loose-Fish—an adaptable survivor.

## Philosophical Voyeurism

He observes the madness around him without being fully consumed by it.

## Radical Tolerance

He willingly shares a bed and worships the idol Yojo with the pagan Queequeg, concluding: Better sleep with a sober cannibal than a drunken Christian.

## Fluid Identity

He is a Presbyterian who recognizes that the universal thump is passed round, rendering all men spiritual equals.



# The *Pequod* as an Isolated Microcosm

## Zone 1: The Quarter-Deck (The Elite)

The realm of ultimate, dictatorial power. Where Ahab paces on his ivory leg, forging his crew's oaths into a single weapon of vengeance.

## Zone 2: The Forecastle (The Proletariat)

The domain of the laborers. A globalized melting pot of mongrel renegades, and castaways, and cannibals.

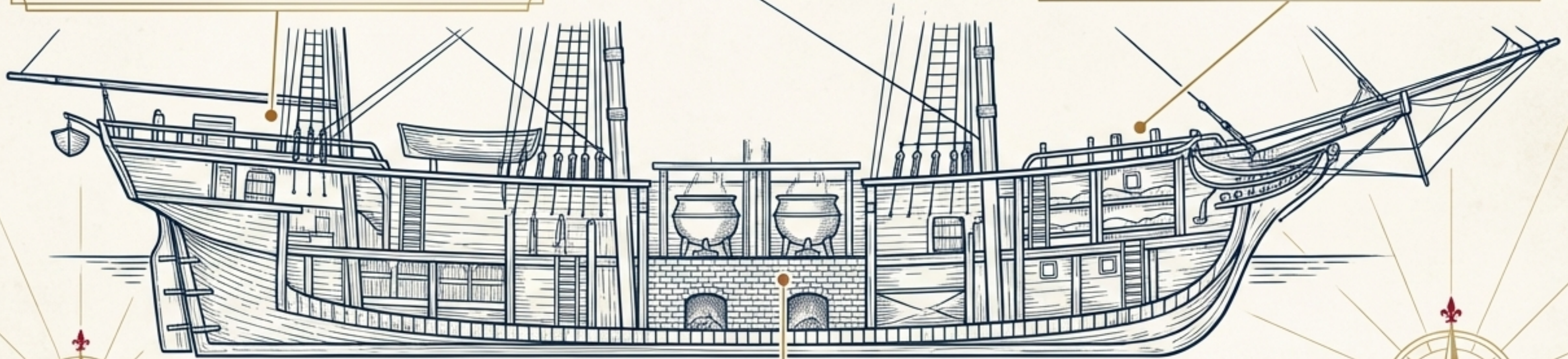

## Zone 3: The Try-Works (The Industrial Hell)

The brick furnaces where blubber is boiled into oil. The literal and metaphorical engine of capitalist consumption and madness.

# The Hierarchy of Worldviews

	Philosophy	View of Nature	Flaw
Starbuck (Chief Mate)	Reason, Piety, Pragmatism.	Respects the ocean. Believes courage arises from a fair estimation of peril.	Unaided virtue is ultimately powerless against Ahab's magnetic madness.
Stubb (2 <sup>nd</sup> Mate)	Indifference, Fatalism, Humor.	The whale is just a meal or a sum of oil.	Invulnerable jollity renders him blind to the true existential horror of the voyage.
Flask (3 <sup>rd</sup> Mate)	Mediocrity, Cruelty, Ignorance.	The whale is merely a magnified mouse to be destroyed.	Utter lack of reverence or deeper thought.

# The Nobility of the Pagan Squires



**Queequeg (South Sea Prince):**  
Possesses innate delicacy and absolute serenity. Saves lives without demanding recognition.



**Tashtego (Gay Head Indian):**  
Inheritor of the proud, unvitiated blood of warrior hunters.



**Daggoo (African Giant):**  
Superb, baronial presence; a noble savage who makes the white crew look diminished.

**Synthesis:** Melville radically subverts the era's prejudices. The non-Christian harpooners possess the true skill, vital force, and honor on the ship, exposing the fragility and ix and hypocrisy of civilized Christendom.

# The Anatomy of Captain Ahab

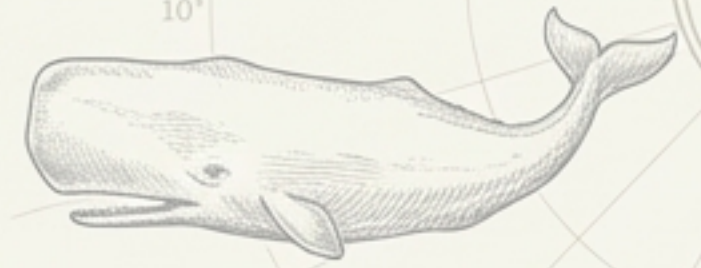

## **The Brain: Monomania.**

Ahab's intellect remains intact, but all his rational faculties are enslaved to a single, irrational obsession.

## **The Heart: The Ungodly, God-Like Man.**

He possesses an archangelic grandeur and a tragic, broken humanity. He pities the madness in others (like Pip) but cannot cure his own.

## **The Ivory Stump: The Transferred Void.**

Ahab transfers all human suffering, malicious agencies, and existential dread onto the physical form of the White Whale. The whale is the pasteboard mask he must strike through.



# Cetology as Narrative Architecture

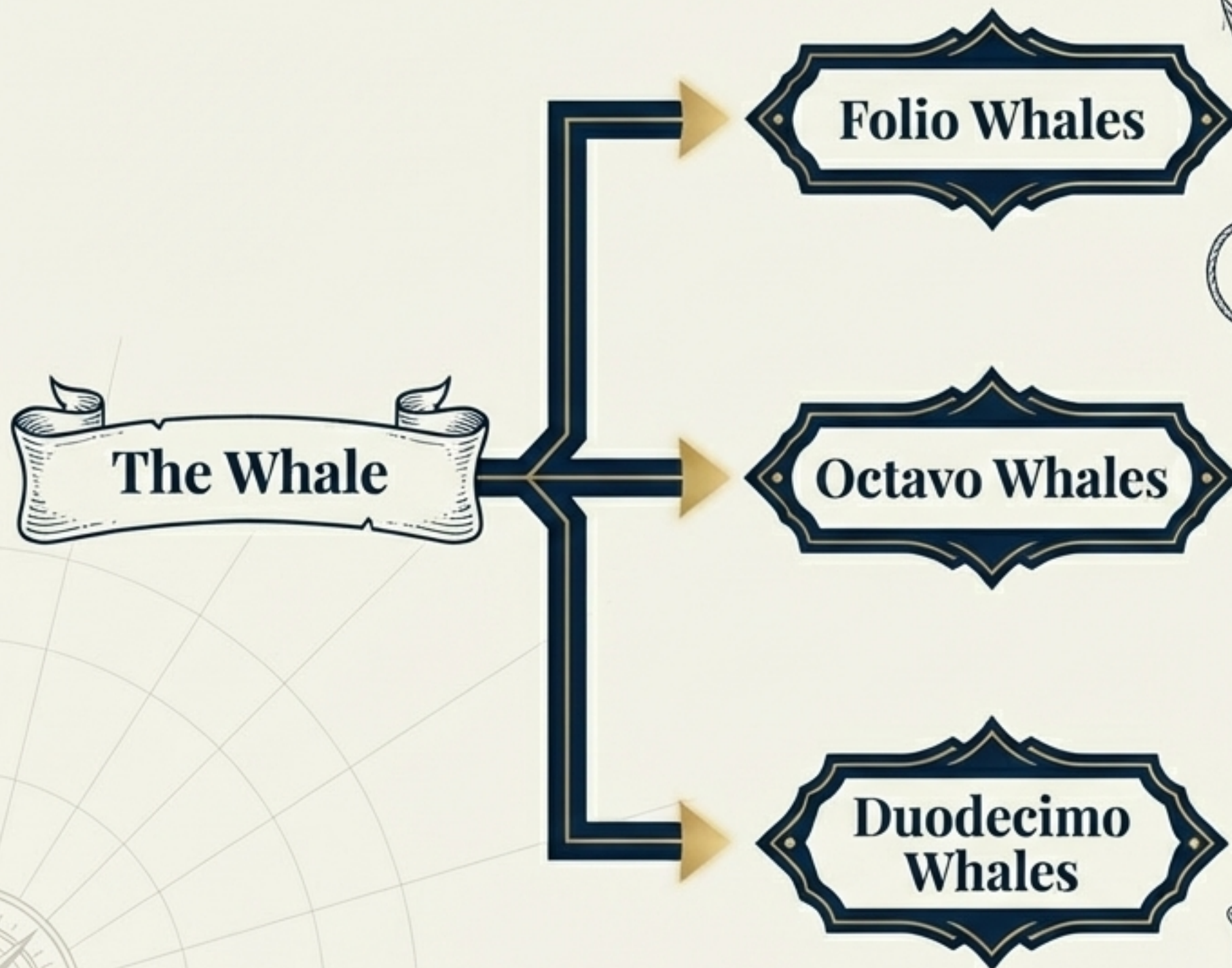

## The Problem

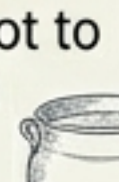

Why does Melville repeatedly halt the plot to describe whale anatomy, ropes, and blubber-boiling?



## The Function

**Grounding the Myth:** Meticulous, exhaustive detailing of the whaling industry forces the reader to accept the reality of the physical world before introducing supernatural dread.

**The Limit of Science:** Melville categorizes the whale by book sizes to show that human science can only classify the surface. The inner mystery of the Leviathan remains completely unreadable.



# Prophets and Pulpits

## Father Mapple



- **The Message:** Preaches the story of Jonah.
- **The Philosophy:** True repentance means submitting entirely to the will of God, even when it demands personal destruction. Woe to him who seeks to please rather than to appal!

## Elijah



- **The Warning:** The ragged, cracked dockside prophet who corners Ishmael before boarding.
- **The Prophecy:** Foreshadows Ahab's doom and his defiance of God. Ishmael dismisses him as a humbug, ignoring the universe's warning signs.

# The Perspectivism of the Doubloon

Nailed to the mast, the gold coin serves as a magician's glass—it means nothing on its own, only mirroring the mind of the man looking at it.

## Ahab

Looks at the towering peaks and sees his own ego. The firm tower, that is Ahab; the volcano, that is Ahab... all are Ahab.

## Starbuck

Looks at the same peaks and sees the Holy Trinity, interpreting the coin as a symbol of heavenly hope amid the dark valley of death.

## Stubb

Looks at the markings and sees the Zodiac, reducing the coin to a crude astrological joke about the inevitability of fate.



# The Try-Works and Industrial Slaughter



## The Scene

The crew, covered in soot and oil, boils the whale's blubber in the dead of night. Ishmael, at the helm, becomes mesmerized by the flames and nearly capsizes the ship.

## The Metaphor

The Pequod becomes a literal floating hell, representing the brutal, soul-destroying reality of early industrial capitalism.

## The Warning

Look not too long in the face of the fire, O man! Melville warns that staring purely into the darkness and malice of the world will invert your soul and blind you to the natural sun.

# Moby Dick in Myth and Reality

## The Myth

Whalemen across the globe believe the White Whale is ubiquitous (seen in two oceans at once) and immortal (swimming away unharmed with groves of spears in his flanks).

## The Trauma

The physical devastation left in his wake. Shattered boats, missing limbs, dead sailors.

## The Reality

A solitary, highly intelligent, albino sperm whale fighting for survival. The malice is a human projection onto an animal defending itself.

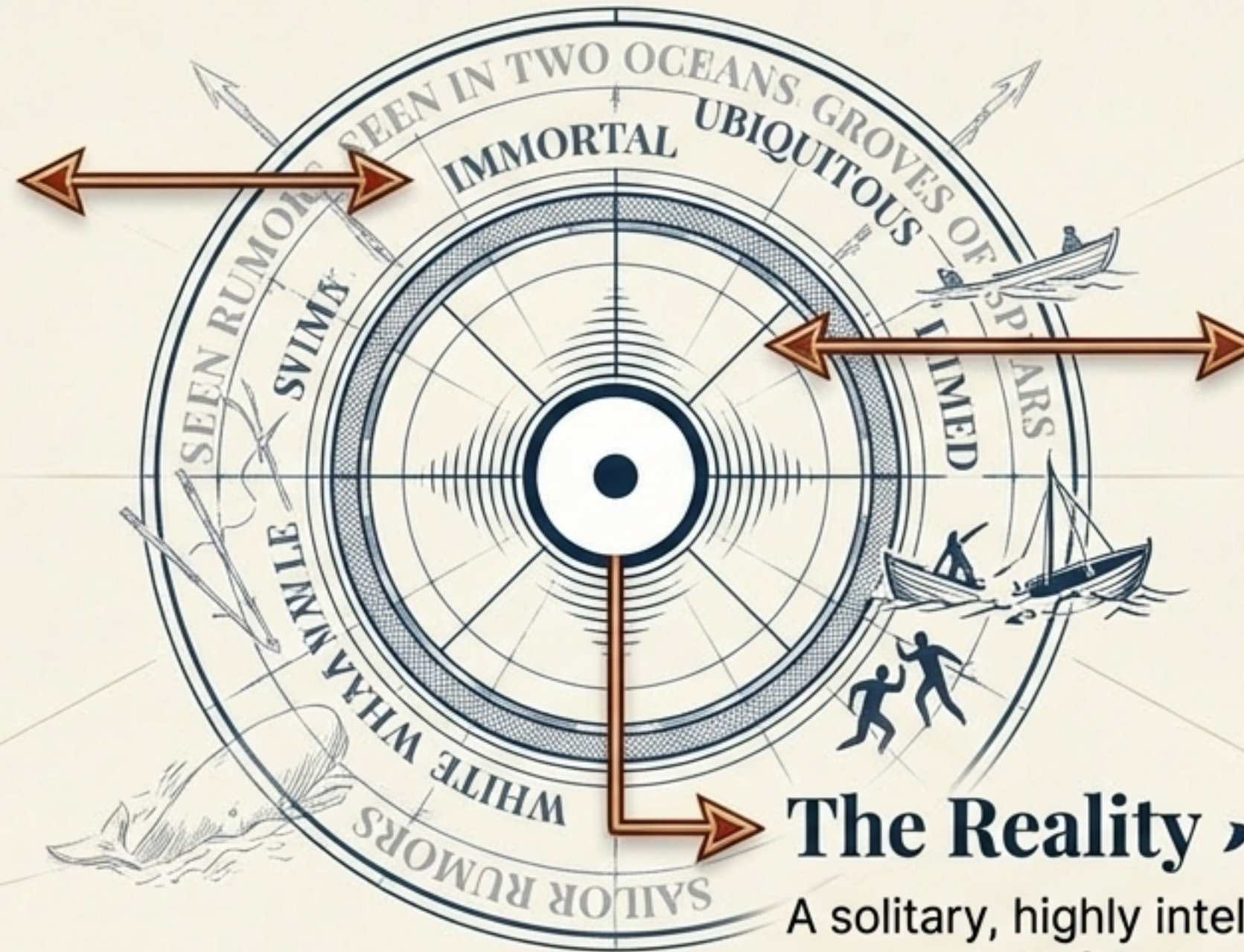

# The Colorless All-Color of Atheism



## The Core Question

Why does the whale's whiteness appal Ishmael more than its deadly jaws?

## The Traditional View

White symbolizes purity, royalty, and the divine veil of the Christian Deity.

## Melville's Subversion

**White is the absence of color.** It represents the heartless voids and immensities of the universe. All beautiful colors of nature are just subtle deceits painted over a dead, indifferent reality.

## The Conclusion

The Albino whale represents the terrifying possibility of a godless, meaningless universe—a monumental white shroud.

# The Law of Fast-Fish and Loose-Fish

## Fast-Fish

A whale connected to a boat by wire or rope belongs to that boat.

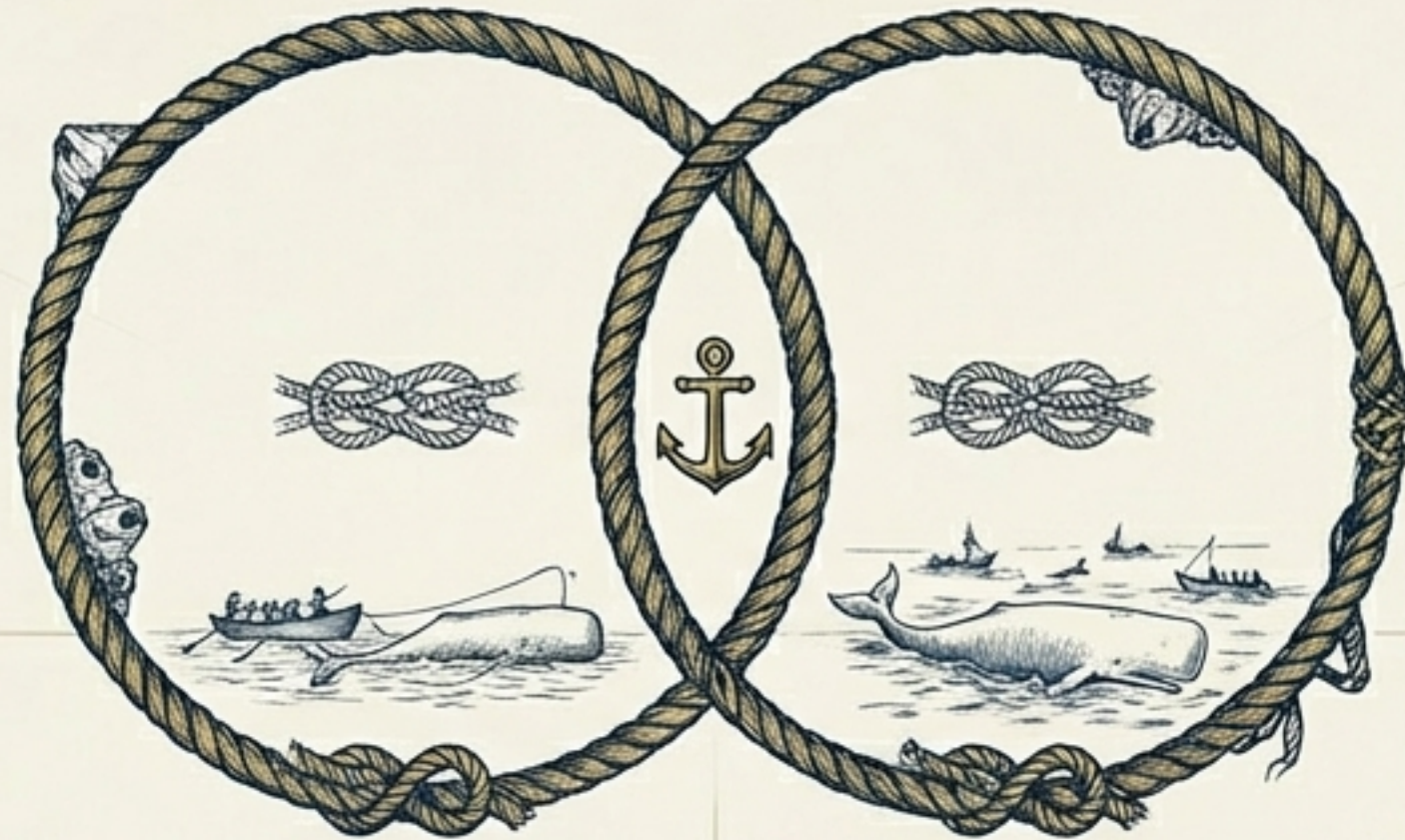

## Loose-Fish

A free-swimming whale is fair game for anybody who can catch it.

## The Philosophical Leap

What was America to Columbus? → A Loose-Fish.  
What is India to England? → A Loose-Fish.  
What are the rights of man? → A Loose-Fish.

**And what are you, reader, but a Loose-Fish and a Fast-Fish, too?**

# The Hempen Bond of the Monkey-Rope



## The Scenario

Queequeg must strip blubber from a dead whale in shark-infested waters. He is tied to Ishmael on the deck by a monkey-rope. If Queequeg falls, Ishmael is dragged into the sea with him.

## The Insight

An elongated Siamese ligature united us. Ishmael realizes his individuality is an illusion. His free will has received a mortal wound, as his survival depends entirely on another man's actions.

## The Theme

A profound metaphor for human brotherhood. No one survives in isolation; we are all tethered to the mistakes and triumphs of our fellow humans.

# The Symphony and the Drop of Pity



## The Calm Before the Storm

On a beautiful, mild day, Ahab finally drops his iron facade while speaking to Starbuck.



## The Confession

He laments his forty years of continual whaling and isolation. He realizes his obsession has turned his young wife into a widow with her husband alive.



## The Tragedy

For a fleeting moment, Ahab sees his own madness. Starbuck begs him to turn the ship home. But the machinery of Fate and Ahab's broken psychology are too strong. He turns away, sealing their doom.

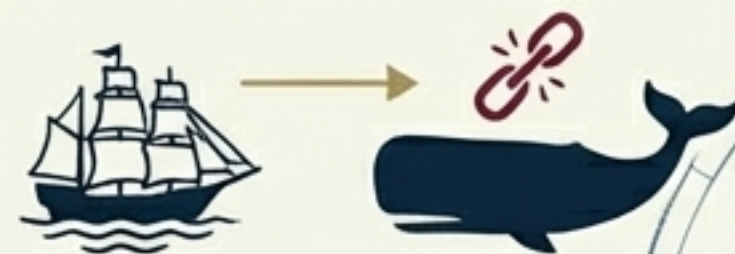

# The Three-Day Chase

## Day 1 (The Warning)



## Day 1 (The Mhale)

Moby Dick bites Ahab's boat in half. The whale shows no initial malice, only defending itself, but Ahab relentlessly pursues.

## Day 2 (The Escalation)

Ahab's ivory leg is shattered. The prophetic Fedallah is lost, dragged down by the whale lines. The crew is driven to a frenzy.



Ahab's ivory leg is shattered. The prophetic Fedallah is lost, dragged down by the whale lines. The crew is driven to a frenzy.



## Day 3 (The Maelstrom)

Moby Dick, maddened, rams the Pequod itself. The ship begins to sink. Ahab, caught in his own harpoon line, is dragged silently to his death.

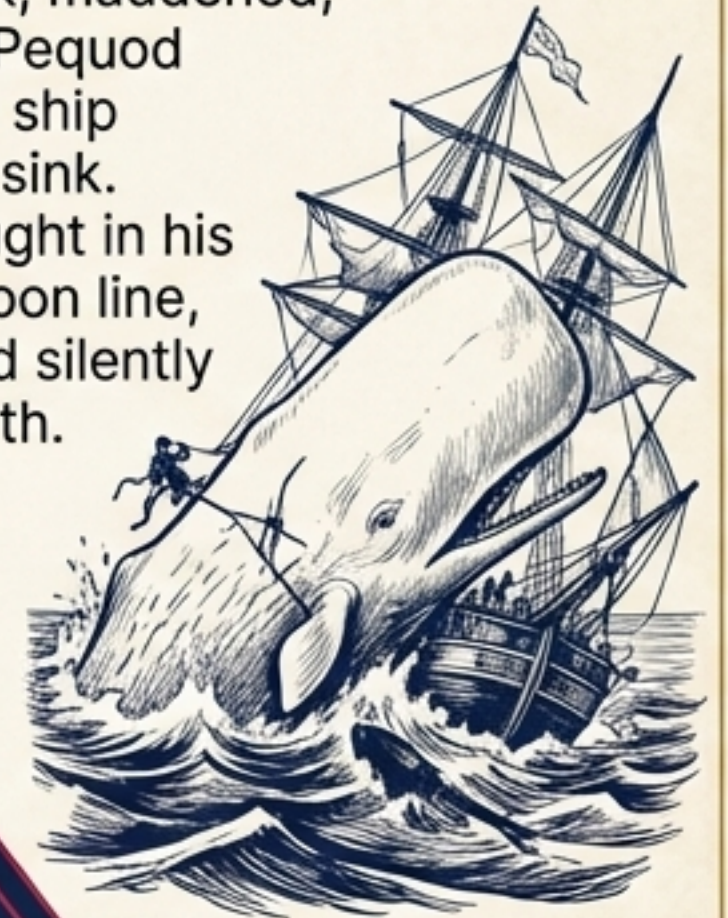

# Survival Through the Life-Buoy Coffin

## The Aftermath

The Pequod sinks, taking the entire crew and the bird of heaven with it. The great shroud of the sea rolled on as it rolled five thousand years ago.



## The Survivor

Ishmael is pulled into the center of the vortex, but survives because **Queequeg's floating coffin**—carved with the mysteries of the universe—shoots to the surface.

## The Final Irony

Life emerges from an instrument of death. The pagan savage provides the salvation for the western Christian. And I only am escaped alone to tell thee.

# Flaws in the Form



## The Critique

Messy structure. Characters vanish. POV shifts randomly. Chapters turn into formatting for Shakespearean stage plays.

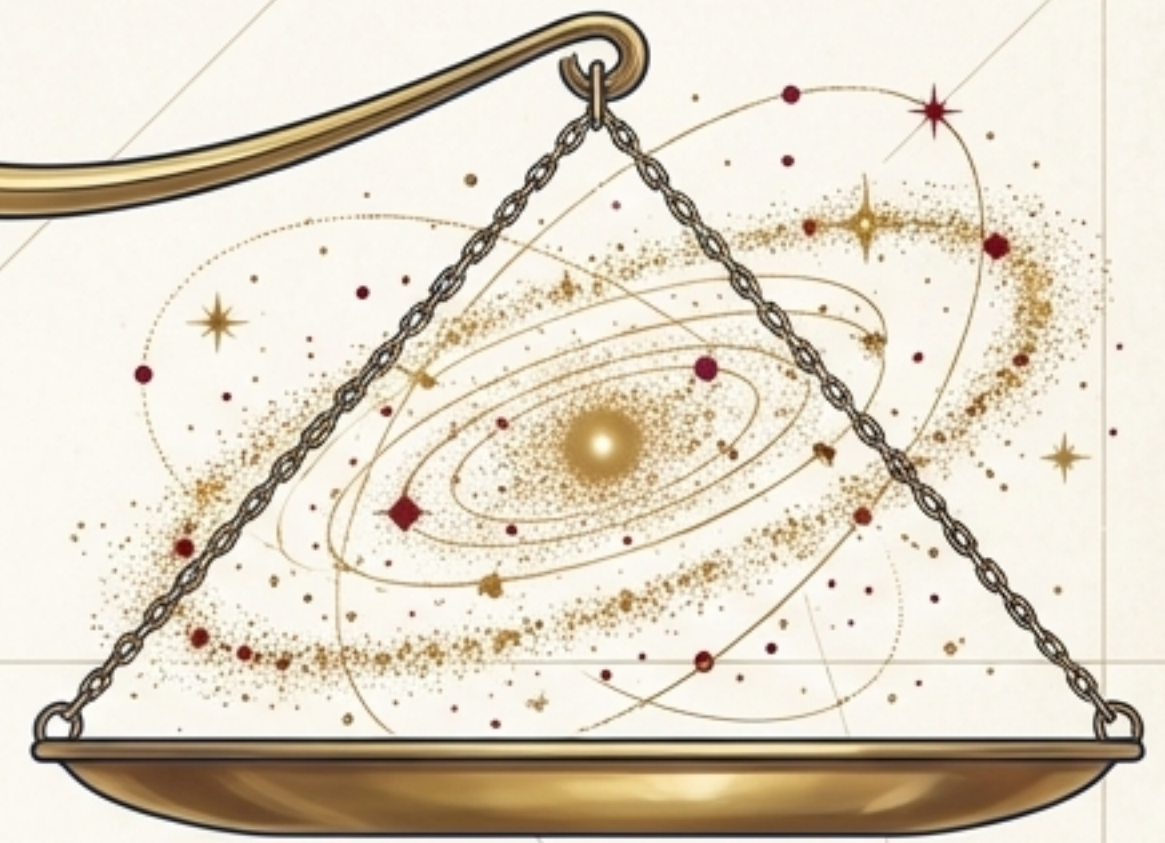

## The Defense

Melville breaks the rules of the traditional novel because his subject cannot be contained by them.

## Synthesis

To capture the infinite, chaotic nature of the universe and the depths of human madness, the very architecture of the book must crack and deform under the weight of its own ambition.



# The Metaphysical Quadrant

Free Will

**Starbuck**

Believes in a moral universe where humans make choices under a benevolent God. (Fails because his framework cannot process pure malice).

**Ishmael**

Accepts that the universe is indifferent and blank (the white whale), but uses his free will to adapt, observe, and survive.

Meaning / God

Meaningless Void

**Ahab**

Believes the universe is heavily orchestrated by malicious, hidden gods, and he is fated to fight them. (Destroys himself and others).



Fate / Determinism

(Note: Stubb exists in a separate state of total avoidance, refusing to engage with the chart at all).



# ❖ The Wisdom That is Woe ❖

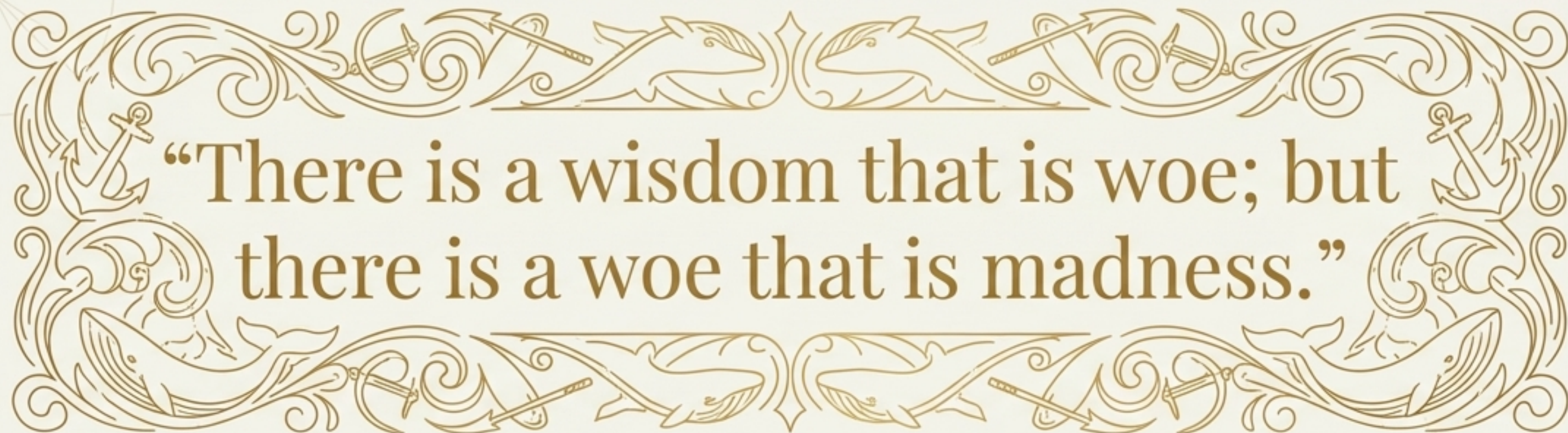

“There is a wisdom that is woe; but there is a woe that is madness.”

<b>The Final Verdict</b>	<b>The Legacy</b>	<b>Rating</b>
<p>Moby Dick is a demanding, sprawling masterpiece. It requires patience for its encyclopedic digressions, but rewards the reader with unmatched prose and terrifying psychological depth.</p>	<p>It stands as the ultimate American tragedy—a warning about the destructive forces of obsession, the machinery of capitalism, and man’s desperate, fatal need to project meaning onto an indifferent universe.</p>	<p>Essential reading for the brave.</p>

